



Republic of the Philippines  
DEPARTMENT OF EDUCATION  
Region VII, Central Visayas  
DIVISION OF CEBU PROVINCE  
Sudlon, Lahug, Cebu City



October 27, 2014

**DIVISION MEMORANDUM**

No. 571 s. 2014

**REGIONAL SINING FESTIVAL OF TALENTS 2015**

To: Assistant Superintendents  
Education Supervisors/Coordinators  
District Supervisors/OICs  
Elementary and Secondary School Heads  
Heads, Private Elementary and Secondary Schools

1. Attached is Regional Memorandum No. 658, s. 2014, entitled, "Regional Sining Festival of Talents 2015".
2. Wide dissemination of this Memorandum is desired.

**ARDEN D. MONISIT, ED. D.**  
**Schools Division Superintendent**

Telephone Numbers:

Schools Division Superintendent: (032) 255-6405  
Asst. Schools Division Superintendent: (032) 414-7457  
Accounting Section: (032) 254-2632  
Disbursing Section: (032) 255-4401

Website: [www.depedcebuprovince.ph](http://www.depedcebuprovince.ph)  
E-mail Add: [depedcebuprovince@yahoo.com](mailto:depedcebuprovince@yahoo.com)



REGIONAL MEMORANDUM

OCT 21 2014

No: 658 s, 2014

REGIONAL SINING FESTIVAL OF TALENTS 2015

To: Schools Division/ City Superintendents  
Officers-in-Charge of Schools Divisions

1. The Regional Festival of Talents will be on February 19-21, 2014 in Tagbilaran City to be hosted by Bohol and Tagbilaran City Divisions. The Festival consists of the following Events/ Area for Skills Exhibition:

1. Sining Tanghalan (5 areas in Arts)
2. Technolympics,
3. Special Program for Foreign Languages,
4. Tagisan Ng Talino,
5. Population Quiz, T.V.
6. Broadcasting (SPJ)

2. Divisions that have School for the Arts are advised to prepare the following entries: (See attached Guidelines and Criteria).

1. Bayle Sa Kalye (Contemporary Street Dance Exhibition based on Locality)
2. Likhawitan (OPM Songwriting Exhibition)
3. Pintabusay (On-the-Spot Painting Exhibition)
4. Sinelikse (Documentary & Video Exhibition)
5. Manik -Aninong Dulaan (Scriptwriting & Shadow Puppetry)

3. The other Activity in the Regional Festival of Talents is the Showdown of the following Categories: (See attached Guidelines and Criteria of the Categories).

- Solo Flute
- Flute Ensemble with Ukulele
- Guitar Solo
- Guitar Ensemble Categories.

4. Below is the list of Divisions that will participate in other activities listed above with their assigned song pieces:

**FLUTE SOLO AND FLUTE ENSEMBLE WITH UKULELE**

Names Divisions	Assigned Song Piece
1. Mandaue	Lagkaw
2. Dumaguete	Habang May Buhay
3. Bohol	Sa Lungsod Sa Buenavista
4. Cebu City	Tanging Yaman
5. Talisay City	Dandansoy

*"Educating for a Strong Republic"*



6. Cebu Province	Matud Mo
7. Danao	Ako Ang Maniid
8. Bogo	Sakayanon
9. Bais	Dalaga Sa Bukid
10. Toledo	Ugoy Ng Duyan
11. Lapulapu	Matud Nila
12. Negros Oriental	Usahay
13. Naga	Paglaum
14. Tagbilaran	Pangandoy Ko Ikaw
15. Guihulgan	Bol -anon/ Pagka Garboso Nga Bukid

#### GUITAR SOLO AND GUITAR ENSEMBLE

Divisions	Assigned Song Piece
* Tanjay	Apple Blossom White
* Mandaue	Half Moon
* Cebu Province	Somewhere My Love
* Talisay	Quando, Quando
* Cebu City	Faithful Love
* Bogo	Can't Help Falling In Love
* Danao	Spanish Eyes
* Dumaguete	Somewhere Over The Rainbow
* Negros Oriental	Tea For Two
* Lapulapu	Rico Vacilon
* Toledo	Cherry Pink
* Bohol	Unchained Melody
* Bais	Annie's Song
* Tagbilaran	Anniversary Song
* Naga	Besame Mucho
* Guihulgan	My Heart Will Go On/ España Cane

5. The Guidelines and Criteria of the other Categories in the Regional Festival of Talents will be issued by the Regional Coordinators.

6. For compliance.

  
**CARMELITA T. DULANGON**  
 Director III  
 Regional Director 

**CULTURAL SHOWDOWN GUIDELINES AND CRITERIA  
ON FLUTE RENDITION, GUITAR PICKING AND GUITAR PLAYING ENSEMBLE,  
ON FEBRUARY 2015**

**I. ELEMENTARY LEVEL**

**A. GUIDELINES AND CRITERIA ON SOLO BAMBOO FLUTE PLAYING WITH UKULELE ACCOMPANIMENT**

1. The Flute Solo Category with ukulele accompaniment is open to all Public Elementary School pupils enrolled in Grades IV-VI (Boy or Girl) for the school year 2014 – 2015.
2. There is no age limit as long as the pupil is enrolled in the specified grade levels.
3. Each entry shall be composed of one (1) flutist and one (1) ukulele accompanist.
4. The official musical piece per Division shall be determined through a drawing of lots done among all Division MAPEH Supervisors and Cultural Coordinators. Musical pieces will be from the song repertoire of the Seminar-Workshop on Flute and Guitar held last July 13 – 15, 2014 at the Applied Nutrition Center, Banilad, Cebu City.
5. Performers will play one (1) Visayan Folk Song.
6. Musical piece to be played during the performance must be memorized.
7. The duration of each performance must be 2-3 minutes only, including the entrance and the exit. Performances which exceed the time limit will automatically be deducted ten (10) points from the total score.
8. Performers must bring their own instruments. Absolutely no flute recorder must be used.
9. Costume of performers must be appropriate to the choice of song.
10. Entry from the Division Level for the Regional Elimination must have undergone the different levels of elimination/competition, to wit:
  - a. School Level
  - b. District Level
  - c. Unit Level
  - d. Congressional Level
  - e. Division Level
11. Results of the School, District, Unit, Congressional, and Division Level, duly signed by the judges, shall be submitted to the Regional MAPEH Supervisor (Dr. Matilde R. Mayonila) as a Division entry for the Regional Elimination process. Performers must be endorsed by the Schools Division Superintendent.
12. Participants must submit the following requirements together with the endorsement for Pre-Elimination. To wit:
  - a. Form 137 (duly signed by the School Principal and Adviser);
  - b. Two (2) pieces 2x2 ID picture;
  - c. Medical Certificate;
  - d. Parent's Permit
  - e. CD (recorded performance)
13. Entry per category must be recorded in CD in MP4 format and submitted on or before November 21, 2014. The Regional Elimination will be on November 27-28, 2014 at the Curriculum and Learning Management Division (CLMD), DepEd Regional Office, Sudlon, Lahug, Cebu City.
14. The decision of the judges is final and irrevocable.
15. The criteria of the contest shall be as follows:

**CRITERIA**

Tone Quality	25%
Musicality (dynamics, tempo, rhythm, phrasing)	25%
Musicianship (skills)	25%
Artistry (expression, interpretation, costume, and choreography)	25%
<b>TOTAL</b>	<b>100%</b>

**B. GUIDELINES AND CRITERIA ON BAMBOO FLUTE AND UKULELE ENSEMBLE**

1. The Bamboo Flute and Ukulele Ensemble Category is open to all Public Elementary School pupils enrolled in Grades 1 -6 for the school year 2014 – 2015.
2. There is no age limit as long as the pupil is enrolled in the specified grade levels.
3. Each group entry shall be composed of 15 -20 members excluding one (1) conductor and/ or coach.
4. The official musical piece per Division shall be determined through a drawing of lots done among all Division MAPEH Supervisors and Cultural Coordinators.
5. Each ensemble will play one (1) Visayan Folk Song with variations.
6. Musical piece to be played during the performance must be memorized.
7. The duration of each performance must be 2-3 minutes only, including the entrance and the exit. Performances which exceed the time limit will automatically be deducted ten (10) points from the total score.
8. Performers must bring their own instruments. **Absolutely no flute recorder is allowed.**
9. Costume of performers must be appropriate to the choice of song.
10. Entry from the Division Level for the Regional Elimination must have undergone the different levels of elimination/competition, to wit:
  - a. School Level
  - b. District Level
  - c. Unit Level
  - d. Congressional Level
  - e. Division Level
10. Results of the School, District, Unit, Congressional, and Division Level, duly signed by the judges, shall be submitted to the Regional MAPEH Supervisor (Dr. Matilde R. Mayomila) as a Division entry for the Regional Elimination process. Performers must be endorsed by the Schools Division Superintendent.
11. Participants must submit the following requirements together with the endorsement:
  - a. Form 137 (duly signed by the School Principal and Adviser);
  - b. Two (2) pieces 2x2 ID picture;
  - c. Medical Certificate;
  - d. Parent's Permit
  - e. CD (recorded performance)
12. Entry per category must be recorded in CD in MP4 format and submitted on or before November 21, 2014. The Regional Elimination will be on November 27-28, 2014 at the Curriculum and Learning Management Division (CLMD), DepEd Regional Office, Sudlon, Lahug, Cebu City.
13. The decision of the judges is final and irrevocable.
14. The criteria of the contest shall be as follows:

**CRITERIA**

Tone Quality and Harmony	25%
Musicality (dynamics, tempo, rhythm, phrasing)	25%
Musicianship (skills)	25%
Artistry (expression, interpretation, costume, and choreography)	25%
<b>TOTAL</b>	<b>100%</b>

## II. SECONDARY LEVEL

### A. GUIDELINES AND CRITERIA ON SOLO GUITAR PLAYING

1. The Solo Guitar Playing Category is open to all Public Secondary School students enrolled in Grades 7 – 9 and in Fourth Year (Boy or Girl) for the school year 2014 – 2015.
2. There is no age limit as long as the student is officially enrolled in the specified grade/year levels.
3. Each entry shall be composed of one (1) guitarist who shall play the music in “picking styles”.
4. The official musical piece per division shall be determined through a drawing of lots done among all Division MAPEH Supervisors and Cultural Coordinators. Musical pieces will be from the song repertoire of the Seminar-Workshop on Flute and Guitar held last July 13 – 15, 2014 at the Applied Nutrition Center, Baniad, Cebu City.
5. Performers will play a medley from the following choices:
  - a. One (1) Visayan Folk Song
  - b. One (1) Visayan Love Song
6. Musical piece to be played during the performance must be memorized.
7. The duration of each performance must be 2-3 minutes only, including the entrance and the exit. Performances which exceed the time limit will automatically be deducted ten (10) points from the total score.
8. The performer must bring his/her own acoustic guitar with or without pick-up sound connectors/cords.
9. Costume of performers must be appropriate to the choice of song.
10. Entry from the Division Level for the Regional Elimination must have undergone the different levels of elimination/competition, to wit:
  - a. School Level
  - b. District Level
  - c. Unit Level
  - d. Congressional Level
  - e. Division Level
11. Results of the School, District, Unit, Congressional, and Division Level, duly signed by the judges, shall be submitted to the Regional MAPEH Supervisor (Dr. Matilde R. Mayonila) as a Division entry for the Regional Elimination process. Performers must be endorsed by the Schools Division Superintendent.
12. Participants must submit the following requirements together with the endorsement:
  - a. Form 137 (duly signed by the School Principal and Adviser);
  - b. Two (2) pieces 2x2 ID picture;
  - c. Medical Certificate;
  - d. Parent’s Permit
  - e. CD (recorded performance)
13. Entry per category must be recorded in CD in MP4 format and submitted on or before November 21, 2014. The Regional Elimination will be on November 27-28, 2014 at the Curriculum and Learning Management Division (CLMD), DepEd Regional Office, Sudlon, Lahug, Cebu City.
14. The decision of the judges is final and irrevocable.
15. The criteria of the contest shall be as follows:

<b>CRITERIA</b>	
Tone Quality	25%
Musicality (dynamics, tempo, rhythm, phrasing)	25%
Musicianship (skills)	25%
Artistry (expression, interpretation, costume, and choreography)	25%
<b>TOTAL</b>	<b>100%</b>

## B. GUIDELINES AND CRITERIA FOR GUITAR ENSEMBLE

1. The Guitar Ensemble Category is open to all Public Secondary School students enrolled in Grades 7 – 9 and in Fourth Year for the school year 2014 – 2015.
2. There is no age limit as long as the student is officially enrolled in the specified grade/year levels.
3. Each entry shall be composed of 15 – 20 guitarists, excluding one (1) conductor and/or coach. Guitar playing will be in “picking and strumming” styles.
4. The official musical piece per Division shall be determined through a drawing of lots done among all Division MAPEH Supervisors and Cultural Coordinators. Musical pieces will be from the song repertoire of the Seminar-Workshop on Flute and Guitar held last July 13 – 15, 2014 at the Applied Nutrition Center, Banilad, Cebu City.
5. Performers will play a medley from the following choices:  
Foreign Music in the style of: Cha-Cha, Tango, Boogie, Rumba, Swing, Salsa, and Waltz.
6. Musical piece to be played during the performance must be memorized.
7. The duration of each performance must be 2-3 minutes only, including the entrance and the exit. Performances which exceed the time limit will automatically be deducted ten (10) points from the total score.
8. The performers must bring their own acoustic guitar with or without pick-up sound connectors/cords.
9. Costume of performers must be appropriate to the choice of song.
10. Entry from the Division Level for the Regional Elimination must have undergone the different levels of elimination/competition, to wit:
  - a. School Level
  - b. District Level
  - c. Unit Level
  - d. Congressional Level
  - e. Division Level
11. Results of the School, District, Unit, Congressional, and Division Level, duly signed by the judges, shall be submitted to the Regional MAPEH Supervisor (Dr. Matilde R. Mayonila) as a Division entry for the Regional Elimination process. Performers must be endorsed by the Schools Division Superintendent.
12. Participants must submit the following requirements together with the endorsement:
  - a. Form 137 (duly signed by the School Principal and Adviser);
  - b. Two (2) pieces 2x2 ID picture;
  - c. Medical Certificate;
  - d. Parent’s Permit
  - e. CD (recorded performance)
13. Entry per category must be recorded in CD in MP4 format and submitted on or before November 21, 2014. The Regional Elimination will be on November 27-28, 2014 at the Curriculum and Learning Management Division (CLMD), DepEd Regional Office, Sudlon, Lahug, Cebu City.
14. The decision of the judges is final and irrevocable.
15. The criteria of the contest shall be as follows:

### CRITERIA

Tone Quality and Harmony	25%
Musicality (dynamics, tempo, rhythm, phrasing)	25%
Musicianship (skills)	25%
Artistry (expression, interpretation, costume, and choreography)	25%
<b>TOTAL</b>	<b>100%</b>

**GUIDELINES AND CRITERIA OF REGIONAL SINING FESTIVAL OF TALENTS  
FOR SCHOOL YEAR THE YR 2014**

**1. Bayle Sa Kalye – Modern Street Dance Parade**

- A total of 25 dancers including instrumentalist and (1) coach.
- Dancers shall dance in 5 minutes progressive steps and 3 minutes exhibition/ ritual on the streets from the starting area of the festival route throughout the end of the festival route.
- After the parade there will be an exhibition presentation.
- Music could be percussive/ CD music with a fusion of Jazz & street dance routines.
- Division Dance Contingents should reflect the local culture based on their place.
- Costumes should be authentic based on their local culture.
- Props is encourage however it should be **hand props** only carried from the starting area of the route till the show down.
- Absolutely no bringing of **back drops**, a deduction of 10 points will be deducted from the total points if contingents will bring back drops.

Criteria for Judging:

Creativity and Originality	25%
Mastery (timing, coordination, discipline& projection)	25%
Costume	25%
Overall Impact/ Hand Props	25%

Total 100%

**11. Likhawitan (OPM) Songwriting Exhibition)**

- The Division winner for Best Composer/ Composition will be the official entry at the Regional Festival of Talents
- Only Schools Division that has School for the Arts can join the competition.
- Only (1) song entry is allowed per Division.
- A maximum of (7) members in a team per Division is allowed. This includes singers, instrumentalists and (1) coach.
- Song must be written in Filipino or in English.
- Songs may be performed in solo, duet, group or band.
- The song writer /s may choose any type of music genre (ballad, rock, etc.) for his / higher composition.
- Song performance must not exceed 10 minutes including instrument and stage set-up.
- The participants should submit the following:
  1. List of participants
  2. Five (4) typewritten lyrics of the song with the title, name of composer and name of performers.
  3. 2 Demo CDs of original song composition.
  4. Performers should bring their own musical instruments. Use of indigenous instruments is highly encouraged.composition on or before November 21, 2014 to the DepEd Regional Office . Attn. Dr. Matilde R. Mayonila.



<b>Criteria of Judging:</b>	
Creativity and Originality of Content	35%
Musicality	35%
Stage Performance (Mastery Costume, Expression/ Diction & Discipline)	30%
<b>Total</b>	<b>100%</b>

**111. Pintahusay (On- the- Spot Painting Exhibition)**

- Only one student participant per Division
- Student participant will be accompanied by one coach.
- Participants must bring the following art materials:
  1. acrylic or oil as medium
  2. canvas 36x 48 inches
  3. Paintbrushes, sponge etc.
- Participants are not allowed to bring pictures or references or images for reference of their entries.
- The subject of Pintahusay will be based on a “**theme**”, which will be given during the event.

**Criteria of Judging:**

* Composition and Visual Impact	25%
* Interpretation of the Theme	25%
* Technique and Style	25%
* Creativity and Originality	25%
<b>Total</b>	<b>100%</b>

**IV. Sineliksi (Documentary Video Exhibition)**

- Participants are required to bring their own laptop/s with video editing software, digital camera or video cameras with computer cable for uploading, tripod and other paraphernalia for video shooting and editing.
- Only one entry per Division is allowed.
- Short film entries should be in DVD, MP4, WMV, or FLV format submitted on the event date. Late submissions will be automatically disqualified.
- Total running time should be 5 to 10 minutes in length, including front and back credits.
- Only 1 entry per Division.
- In a team (2 filmmaker/s and 1 coach) per region is allowed.
- The video should be in Filipino and/ or English.
- Videos should be an original work of the student-participants and shall not infringe on any copyright or any rights of any third parties.
- Music and images presented in the film should be taken during the 2015 Regional Sining Festival of Talents.
- Theme of the film will be given upon registration.

<b>Criteria for Judging:</b>	
• Narrative Flow	30%
• Cinematography	30%
• Use of Music & Sound Effects	10%
• Editing and Use of Visual Enhancements	20%
• Overall Impact	10%
<b>Total</b>	<b>100</b>

V. **Manik –Animong Dulaan (Scriptwriting & Shadow Puppetry Exhibition)**

- Only one (1) entry per Division is allowed.
- A maximum of 7 members in a team per Division (scriptwriter/s, puppet master/s and coaches/es) is allowed .
- \* Each entry should only run for 15 minutes including set-up, actual performance and exit.
- Script must be in Filipino and/ or English.
- Props (special effects, colored lights, LCD, etc. should be provided by the participants.
- Puppets should be clear enough to be seen onstage.
- Puppet theater dimension should be as follows:

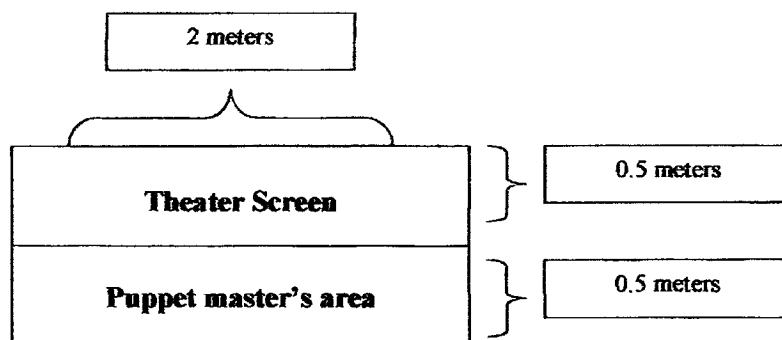

- Music and Sound effects are highly encouraged.
- Theme of the play should revolved around any of the following issues:
  1. Social
  2. Political
  3. Environmental
  4. Health
- Script should be an original work of the student-participants and shall not infringe on any copyrights or any rights of any third parties.
- Four (4) encoded scripts with the title, name of the writer/s and name of performer/s must be submitted on the Registration Day.
- Criteria for Judging:
 

1. Creativity and Originality	30%
2. Performances (actors & actresses)	20%
3. Production Design (props, costumes, etc.)	20%
4. Use of Music & Sound Effects	20%
5. Visual Impact	10%
<b>Total</b>	<b>100%</b>